



REDWOOD VALLEY-CALPELLA FIRE DISTRICT

- Delbert Phelps Fire House
 - 8481 East Road
- Redwood Valley CA 95470
Phone: 707-485-8121

www.redwoodvalleycalpellafire.org

BOARD OF DIRECTORS

Joe Cooper

Stephanie Dunken

Ryan Mayfield

Russel Odell

James Tusso

REGULAR MEETING AGENDA

Thursday, October 9, 2025 at 6:00PM

Any person who requires a disability related modification or accommodation in order to participate in a public meeting should make such a request to Jessica Keizer, Board Clerk, for immediate consideration.

1. Opening Business

- 1.1 Call to Order
- 1.2 Pledge of Allegiance and Moment of Silence
- 1.3 Roll Call

2. Public Comment (GC §54954.3)

This portion of the meeting is reserved for persons wishing to address the Board on any matter not on the agenda. Any matter that requires Board action will be referred to staff for a report and action at a subsequent Board meeting.

3. Agenda Amendments (GC §54954.2) – Discussion/Action

4. Consent Calendar

(Consent calendar items will be enacted upon by one motion. There will be no separate discussion on items unless a Board Member, Staff, or member of the public requests removal of the item for separate action.)

- 4.1 Minutes: Approve Regular Board Meeting Minutes of September 11, 2025
- 4.2 Minutes: Approve Special Board Meeting Minutes of September 25, 2025
- 4.3 Payroll: Approve Payroll 18 and 19 in the amount of: \$50,263.28
- 4.4 Expenditures: Approve Expenditures for September in the Amount of:
 - General Fund with CalCard Details: \$23,000.08

5. Action Items – Discussion/Action

- 5.1 Review and Approve an Employment Agreement for the Fire Chief Position and Authorize the Board Chair to Sign on Behalf of the Board - Discussion/Action
- 5.2 Review and Approve a Revision to the Employee Benefits (Full-Time/Permanent Duty Officer) Operating Procedure (OPM 3.23) - Discussion/Action
- 5.3 Review and Approve the Purchase of a Tank and Pump for the New Duty Officer Vehicle (Squad 6231) - Discussion/Action
- 5.4 Review and Approve Outdoor Warning Siren – Operating Procedure (OPM 3.24) – Discussion/Action

6. Board of Directors and Administrative Reports – Information/Discussion

(No action will be taken on any questions raised by the Board at this time.)

- 6.1 Board of Directors Report
Human Resources Committee (Ad Hoc – Dunken and Odell)
- 6.2 Fire Chief Report
- 6.3 Volunteers Reports (Fire Marshal, Training Officer and Safety Officer)
- 6.4 Volunteer Association Report

7. Correspondence – Information

8. Request for Future Agenda Items

9. Closed Session: Government Code §54957

- 9.1 Fire Chief: Government Code §54957.(b)(1)
- 9.2 Interim Fire Chief Performance Review: Government Code §54957.(b)(1)

10. Open Session

- 10.1 Report on Closed Session: Government Code §54957.1

11. Adjournment

Next Regularly Scheduled Board Meeting
Thursday, November 13, 2025 at 6 p.m.



**REDWOOD VALLEY-CALPELLA FIRE DISTRICT
BOARD OF DIRECTORS REGULAR MEETING
MINUTES
September 11, 2025**

Page 1 of 6

1. Opening Business

1.1 Call to Order

The meeting was called to order by Chair Dunken at 6:00 PM.

1.2 Pledge of Allegiance and Moment of Silence.

1.3 Roll Call

X Director Cooper X Chair Dunken X Director Mayfield X Director Odell X Director Tuso

Staff present: Interim Fire Chief Grebil, Jessica Keizer.

2. Public Comment (GC §54954.3)

None

3. Agenda Amendments (GC §54954.2)

None

4. Consent Calendar

4.1 Minutes: Approve Regular Board Meeting Minutes of August 14, 2025

4.2 Payroll: Approve Payroll 15,16,17 and ABH 2024 in the amount of: \$114,048.11

4.3 Expenditures: Approve Expenditures for August in the amount of:
General Fund: \$49,407.97

Director Tuso made a motion, seconded by Director Odell, to approve the consent calendar.

Ayes: Cooper, Mayfield, Odell, Tuso, Dunken

Noes:

Absent:

Abstain:

Motion passes



**REDWOOD VALLEY-CALPELLA FIRE DISTRICT
BOARD OF DIRECTORS REGULAR MEETING
MINUTES
September 11, 2025**

Page 2 of 6

5. Action Items – Discussion/Action

5.1 Public Hearing: Ordinance 2025-02, an Ordinance of the Redwood Valley-Calpella Fire District, Adopting the 2025 Edition of the California Fire Code part 9 and the 2025 Edition of the California Wildland-Urban Interface Code part 7 with amendments - Discussion/Action

Public Hearing opened at 6:08PM with no further questions or comments it was closed at 6:09PM.

Director Cooper made a motion, seconded by Director Odell, to waive the reading and adopt Ordinance 2025-02 the recommended action and approve Resolution #2025-2, adopting the 2025 Edition of the California Fire Code part 9 and the 2025 Edition of the California Wildland-Urban Interface Code part 7 with amendment.

Ayes: Cooper, Mayfield, Odell, Tusso, Dunken

Noes:

Absent:

Abstain:

Motion passes

5.2 Review and Approve the Purchase of 2,000 feet of 3” Fire Hose - Discussion/Action

A brief history was given on the fitting that was found on the engine that RVCFD recently acquired. Then the Board reviewed the quotes for the fire hose with the recommendation to purchase from the vendor with the lowest quote.

Director Cooper made a motion to approve the recommended action to authorize the purchase of 2,000 feet (40 X 50') of 3" Fire hose from AllStar Fire Equipment with a second from Director Mayfield.

Ayes: Cooper, Mayfield, Odell, Tusso, Dunken

Noes:

Absent:

Abstain:

Motion passes



**REDWOOD VALLEY-CALPELLA FIRE DISTRICT
BOARD OF DIRECTORS REGULAR MEETING
MINUTES
September 11, 2025**

Page 3 of 6

5.3 Review and Approve the Purchase of a Replacement Light Rescue Unit Utilizing PG&E Settlement Funds - Discussion/Action

Per the Fleet Replacement Plan the next vehicle identified to be replaced is the current rescue 6230. The Board reviewed the specifications of the proposed vehicle and discussed the funds remaining in the PG&E Settlement funds.

The recommendation is to approve the purchase of a new FORD F-550 rear axle drive 4x4, dual rear wheels (DRW), four (4) door crew cab and chassis with XL trim and 6.7L Power Stroke V8 Turbo Diesel Engine/Fouts Fire 9" Light Rescue Unit, from Fire Apparatus Solutions of Rialto, California, in the amount of \$329,746.91, utilizing the H-GAC Cooperative Purchasing Agreement. And authorize the Board Chair to execute the necessary County contracts for the use of PG&E Settlement Funds for the purchase of the Light Rescue with the total project cost estimated to be \$360,000.00.

Director Mayfield made a motion to approve the recommended action to authorize the purchase of a new FORD F-550 rear axle drive 4x4, dual rear wheels (DRW), four (4) door crew cab and chassis with XL trim and 6.7L Power Stroke V8 Turbo Diesel Engine/Fouts Fire 9" Light Rescue Unit, from Fire Apparatus Solutions of Rialto, California, in the amount of \$329,746.91, utilizing the H-GAC Cooperative Purchasing Agreement. And authorize the Board Chair to execute the necessary County contracts for the use of PG&E Settlement Funds for the purchase of the Light Rescue with the total project cost estimated to be \$360,000.00 with a second from Director Odell.

Ayes: Cooper, Mayfield, Odell, Tusso, Dunken

Noes:

Absent:

Abstain:

Motion passes

5.4 Review and Approve Outdoor Warning Siren – Operating Procedure (OPM 3.24) – Discussion/Action

A discussion ensued regarding the proposed Outdoor Warning Siren. Chair Dunken brought forward questions regarding the code that grants the authority to sound an evacuation warning and the liability that the District has when sounding the siren to evacuate. It was determined that while the Board would like to see this procedure go into place they would like to have it reviewed by legal counsel before approving.



**REDWOOD VALLEY-CALPELLA FIRE DISTRICT
BOARD OF DIRECTORS REGULAR MEETING
MINUTES
September 11, 2025**

Page 4 of 6

Director Mayfield made a motion to authorize staff to send the policy to the attorney to be reviewed with a second from Director Cooper.

Ayes: Cooper, Mayfield, Odell, Tusso, Dunken

Noes:

Absent:

Abstain:

Motion passes

5.5 Review and Approve Preventative Maintenance, Training and Testing of the Outdoor Warning Siren Utilizing PG&E Settlement Funds– Discussion/Action

This item was tabled to be discussed at the next meeting.

6. Board of Directors and Administrative Reports – Information/Discussion

(No action will be taken on any questions raised by the Board at this time.)

6.1 Board of Directors Report

Human Resources Committee (Ad Hoc – Dunken and Odell) -None

6.2 Fire Chief Report

63 Incidents including 0 fires for July 2025

59 Incidents including 2 fires for August 2025

August training topics included:

New Pediatric Cardiac Arrest Protocols, Wildland Urban Interface (in field exercise), Post Incident Analysis of Road E Fire, and Rescue Ropes.

Personnel:

Career - Acting Fire Apparatus Engineer/Duty Officer in training

Volunteer - Roster = 23



**REDWOOD VALLEY-CALPELLA FIRE DISTRICT
BOARD OF DIRECTORS REGULAR MEETING
MINUTES
September 11, 2025**

Page 5 of 6

Equipment: Surplus Equipment Sold - AED's, Portable Radios, Rescue Air System and Hydraulic Auto Extrication Tools totaling \$3,320

New Water Tender 6291 towed to Sacramento KW for warranty repairs. Fouts dealer demo/loaner water tender in service.

E6280 (Surplus OES Engine) picked up and prepared for color wrap.

Issued/Donated two surplus mobile radios to Covelo FPD for Chief Rojas' vehicle and four surplus portable radios to the Ridgewood Ranch Volunteer FD.

6.3 Volunteers Reports (Fire Marshal, Training Officer and Safety Officer)

Fire Marshal- None

Training Officer- It was reported that RVCFD is working on rope rescue training this month. Next month it will be vehicle extrication and RVCFD will be hosting a class for the local Chief's Academy. November is going to be PSFA training.

Safety Officer- It was reported that we ended up with surplus Wildland PPE which was used to outfit the Explorers. A safety reminder was given to all that engines should not idle in the bays. The Drip Drop hydration powder packs that we received were greatly appreciated on the most recent structure fire.

6.4 Volunteer Association Report-

The Volunteer Association reported that they are having the newly purchased engine 6280 wrapped and new rims are being installed. The Explorers will be purchasing new gear racks. New roll up doors will be purchased for the water tender 6290 to promote ease of use and safety over the existing doors. And the "Thank You" Chicken BBQ is fast approaching on 9/27/2025.

7. Correspondence – Information

7.1 None

8. Request for Future Agenda Items

None

9. Closed Session: Government Code §54957



**REDWOOD VALLEY-CALPELLA FIRE DISTRICT
BOARD OF DIRECTORS REGULAR MEETING
MINUTES
September 11, 2025**

Page 6 of 6

Closed Session entered into at 7:19PM

- 9.1 Fire Chief Recruitment: Government Code §54957. (b)(1)**
- 9.2 Interim Fire Chief Performance Review: Government Code §54957. (b)(1)**
- 10. Open Session reconvened at 8:05PM**
- 10.1 Report on Closed Session: Government Code §54957.1**

No action was taken in closed session on items 9.1 and 9.2.

11. Adjournment at 8:06PM

There being no further business to come before the Board the meeting was adjourned at 8:06PM.

The next Regular Board Meeting will be October 9, 2025 at 6:00PM

Stephanie Dunken, Chair

Jessica Keizer, Clerk



REDWOOD VALLEY-CALPELLA FIRE DISTRICT

- Delbert Phelps Fire House
 - 8481 East Road
- Redwood Valley CA 95470
Phone: 707-485-8121

www.redwoodvalleycalpellafire.org

BOARD OF DIRECTORS

Joe Cooper

Stephanie Dunken

Ryan Mayfield

Russel Odell

James Tuso

SPECIAL MEETING MINUTES

Thursday, September 25, 2025 at 1:00PM

Wyndham Garden Redwood Valley - 101 Coyote Valley Blvd. - Redwood Valley, CA 95470

1. Opening Business

- 1.1 Call to Order by Chair Dunken at 1:06 p.m.
- 1.2 Roll Call – Present = Directors Cooper, Dunken, Mayfield and Odell
Absent = Director Tuso

2. Public Comment (GC §54954.3)

None

3. At 1:08 p.m. the Board went into Closed Session for the purposes listed below:

- 3.1 Fire Chief Recruitment: Government Code §54957.(b)(1)
The Board will be briefed by the interview panels and then interview the Fire Chief candidates.
- 3.2 Conference with Labor Negotiators: Government Code §54957.6
Agency Designated Representatives: Directors Dunken, Odell and Interim Fire Chief Grebil
Employee: Fire Chief
The Board may provide direction to the Labor Negotiators for the development of an employment agreement for the Fire Chief.

4. Open Session at 4:57 p.m.

- 4.1 Report on Closed Session: Government Code §54957.1

As to 3.1, Chair Dunken reported that the Board met with the interview panel members and then interviewed the Fire Chief candidates.

The Board directed Interim Fire Chief Grebil to tender a conditional job offer to the Board's number one candidate and to begin the background check process including a medical screening.

As to 3.2, the Board gave direction to the Labor Negotiators and directed Interim Fire Chief Grebil to share a draft employment agreement with the Board's number one candidate.

5. Adjournment at 4:58 p.m.

Redwood Valley Calpella Fire District

Payroll details report

From Sep 01, 2025 to Sep 30, 2025 for all employees from all locations

| Pay date | Name | Hours | Gross pay | Other pay | Employee taxes & deductions | Net pay | Employer taxes & contributions | Total payroll cost |
|--------------|------|---------------------------------------|--------------------|-----------|---------------------------------------|--------------------|-------------------------------------|--------------------|
| Total | | Gross 1427.5h | \$46,011.74 | | Employee taxes - \$9,407.40 | \$35,171.10 | Total \$4,251.54 | \$50,263.28 |
| | | Regular Pay 778.5h | \$26,833.23 | | Federal Income Tax -\$4,038.59 | | Employer taxes \$3,624.53 | |
| | | FLSA OT 133.5h | \$1,507.31 | | Social Security -\$2,724.78 | | Social Security Employer \$2,724.78 | |
| | | Sick Pay 114h | \$2,896.50 | | Medicare -\$637.26 | | Medicare Employer \$637.26 | |
| | | Vacation Pay | \$0.00 | | CA Income Tax -\$1,479.38 | | CA ETT \$0.00 | |
| | | Holiday Pay | \$0.00 | | CA State Disability Ins -\$527.39 | | CA SUI Employer \$262.49 | |
| | | Cell Phone Reimbursement | \$0.00 | | Aftertax deductions - \$426.08 | | Contributions \$627.01 | |
| | | Salary | \$0.00 | | Garnishment - Child Support -\$375.68 | | Simple IRA \$0.00 | |
| | | Safety Officer Stipend | \$250.00 | | CA FTB PIT Garnishment \$0.00 | | CalPERS 457 Retirement \$627.01 | |
| | | Training Officer Stipend | \$500.00 | | 08/29/25 Overpaid -\$50.40 | | | |
| | | Expense Reimbursement | \$324.80 | | | | | |
| | | Promotion Rate 12/21/24 | \$0.00 | | | | | |
| | | Volunteer Pay | \$0.00 | | | | | |
| | | 1014 ABH 2024 | \$0.00 | | | | | |
| | | QRDO Stipend | \$2,600.00 | | | | | |
| | | Travel per Diem | \$1,739.00 | | | | | |
| | | Chief Hourly | \$0.00 | | | | | |
| | | Fire Marshal Stipend | \$500.00 | | | | | |
| | | 1012 Seasonal FF 271h | \$5,677.45 | | | | | |
| | | 1013 Extra Hours 130.5h | \$3,183.45 | | | | | |
| | | 1012 Seasonal FF New Rate | \$0.00 | | | | | |
| | | Pretax deductions - \$1,007.16 | | | | | | |
| | | Simple IRA \$0.00 | | | | | | |
| | | CalPERS 457 Retirement -\$1,007.16 | | | | | | |
| | | Adjusted gross \$45,004.58 | | | | | | |

| Date | Num | Vendor | Memo | Amount |
|--------------|--------------|--|---|---------------------|
| 09/03/2025 | 3713 | AT&T | Station Phone Lines | -112.61 |
| 09/03/2025 | 3714 | S&L Controller Services | Accounting Services | -1,714.86 |
| 09/03/2025 | 3715 | Special District Risk Management Authority | Employee Medical Insurance Premiums | -2,018.93 |
| 09/08/2025 | EFT 9/8/25 | CalPERS | Annual Social Security Administrator Fee | -100.00 |
| 09/09/2025 | 3718 | Med-Tech Resource, Inc. | Grant Funded EMS Supplies | -266.40 |
| 09/09/2025 | 3719 | Mendocino County Auditor-Controller | Local Agency Formation Commission (LAFCO) Annual Fees | -3,879.06 |
| 09/09/2025 | 3720 | Special District Risk Management Authority | Employee Medical Insurance Premiums | -2,018.93 |
| 09/04/2025 | ACH 9/4/2025 | U.S. Bank | See CalCard Detail | -7,629.54 |
| 09/16/2025 | 3721 | City of Ukiah | Station Water | -68.54 |
| 09/16/2025 | 3722 | Nick Barbieri Trucking | Diesel Fuel | -1,329.00 |
| 09/23/2025 | 3723 | Curtis Tools | Wildland Personnel Protective Equipment | -1,319.00 |
| 09/23/2025 | 3724 | FleetPride | Repair Parts | -114.29 |
| 09/23/2025 | 3725 | George Petersen Insurance Agency | Premium Adjustment (delete/add vehicles) | -616.20 |
| 09/23/2025 | 3726 | PG&E | Station Electric and Gas | -1,565.62 |
| 09/23/2025 | 3727 | Speedy Signs | Renumber 6267 to 6260 | -161.81 |
| 09/23/2025 | 3728 | Ukiah Daily Journal | Public Notice Ad | -85.29 |
| TOTAL | | | | -\$23,000.08 |
| | | | | |
| | | | | |
| | | | | |

CAL-Card August 2025 Charges

| <i>Vendor</i> | <i>Description</i> | <i>Amount</i> | <i>Budget Code</i> |
|----------------------------|---|-------------------|--------------------|
| Redwood Valley Station | Redwood Valley Station | \$91.02 | 86-2250 |
| FDAC | Fire Districts Assoc of CA Annual Membership | \$250.00 | 86-2150 |
| Amazon | Folders/Label tape/Pens/Labels | \$82.53 | 86-2170 |
| Amazon | No Parking-Fire Lane Signs | \$54.32 | 86-2130 |
| Amazon | Yellow Cardstock/Orange Paper | \$31.78 | 86-2170 |
| Streamline | Website-RVCFD Monthly | \$206.00 | 86-2170 |
| Google | Google Workspace Monthly Billing | \$105.40 | 86-2170 |
| Redwood Waste Solutions | Monthly garbage service | \$128.24 | 86-2090 |
| Smart Tech | K.Robinson Computer Diagnostic | \$55.00 | 86-2170 |
| Ukiah Daily Journal | Job Posting-Fire Chief (8 Days) | \$678.00 | 86-2190 |
| Amazon | Flashlight Batteries | \$323.58 | 86-2120 |
| AT&T | Tablets/District Cell Phone | \$190.35 | 86-2060 |
| Amazon | Replacement Ice Scoop | \$18.19 | 86-2090 |
| Xfinity | Internet-Monthly | \$92.00 | 86-2170 |
| International Code Council | 2025 California Fire Code | \$293.96 | 86-2190 |
| International Code Council | 2025 CA Wildland Urban Interface Code | \$113.81 | 86-2190 |
| LN Curtis | Cancel Order Return spanner set 6291 | -\$400.06 | 86-4370 |
| BK Fire Radios | Portable Radio Repair Parts | \$45.95 | 86-2120 |
| Andax | Flashlight 6261 | \$69.10 | 86-2220 |
| Ebay | Station Radio Alert Amp | \$137.45 | 86-2220 |
| B+H Audio | Station Radio Alert Module | \$75.46 | 86-2220 |
| B+B Industrial Supplies | WT6291 Repair/ Install Parts | \$89.20 | 86-2120 |
| Coyote Valley Gas | Gas-6200 | \$79.00 | 86-2250 |
| B+B Industrial Supplies | WT6291 Repair/ Install Parts | \$87.44 | 86-2120 |
| P+W Service Center | Radio Pager/Amp Charger for station alert sys | \$629.25 | 86-2220 |
| Andax | B/O Flashlight Charger 6261 | \$34.90 | 86-2220 |
| Mendo Mill | Plumbing Parts for extractor | \$38.10 | 86-2130 |
| Wayfair | Wardrobe X 3 Crews Quarters | \$1,003.21 | 86-2090 |
| Lindberg Lumber | Plumbing and Electrical Supplies-Repairs | \$52.98 | 86-2130 |
| Amazon | Bed Frame, mattress, bedding X 3 Crews Q #1 | \$711.84 | 86-2090 |
| Amazon | Bed Frame, mattress, bedding X 3 Crews Q #2 | \$352.68 | 86-2090 |
| Amazon | Yeti drain valve/hose ice chests 6281/6261 | \$32.34 | 86-2080 |
| Friedmans | Plumbing and Drain for Extractor | \$134.22 | 86-2130 |
| Home Depot | Flooring for Crews Quarters | \$1,329.55 | 86-2130 |
| Mendo Mill | Plumbing for Extractor and Gas | \$45.94 | 86-2130 |
| Mendo Mill | Staple gun/staples/hose nozzles | \$119.59 | 86-2130 |
| Lindberg Lumber | Paint thinner | \$10.78 | 86-2130 |
| Friedmans | Baseboard for Crews Quarters | \$229.94 | 86-2130 |
| Home Depot | Flooring Underlayment- Crews Quarters | \$84.92 | 86-2130 |
| Home Depot | Return-Flooring Underlayment | -\$84.92 | 86-2130 |
| Home Depot | Base Board Screws - Crews Quarters | \$6.50 | 86-2130 |
| O'Reilly | Struts 13" for 6290 compartment doors | \$47.77 | 86-2120 |
| O'Reilly | Return Struts 13" for 6290 compartment doors | -\$47.77 | 86-2120 |
| | | | |
| | Total Charges: | \$7,629.54 | |

Budget Totals:

| | | |
|---------|-------------------------|------------|
| 86-2050 | PPE | \$0.00 |
| 86-2060 | Telephone/Communication | \$190.35 |
| 86-2080 | Food | \$32.34 |
| 86-2090 | Household | \$2,214.16 |
| 86-2120 | Maint/Repair-Vehicles | \$546.17 |
| 86-2130 | Building Maint | \$2,021.92 |
| 86-2150 | Memberships | \$250.00 |

| | | |
|---------|--|-------------------|
| 86-2170 | Supplies-Office | \$572.71 |
| 86-2187 | Training | |
| 86-2190 | Publications | \$1,085.77 |
| 86-2220 | Small Tools | \$946.16 |
| 86-2239 | Special Dept Expense | |
| 86-2250 | Travel/Transportation/Gas | \$170.02 |
| 86-4370 | Fixed Assets (New F/A Water Tender 6291) | -\$400.06 |
| | Total: | \$7,629.54 |

**REDWOOD VALLEY-CALPELLA
FIRE DISTRICT
Operating Procedures Manual**

OPM 3.23

Employee Benefits (Full-Time/Permanent Duty Officer)

Page 2 of 12

Captain –

- (a) Successful completion of any four (4) State Fire Officer courses.
- (b) Certification as a State Fire Officer.

Fire Apparatus Engineer –

- (a) Successful completion of Driver/Operator 1A & 1B
- (b) Successful completion of any two (2) State Fire Officer courses.

Salary Upon Promotion

When employees are promoted, they shall normally receive the first step in the salary range for their new position. ~~However, if such step results in a salary increase of less than five percent (5%), they shall receive a minimum of five percent (5%) increase, provided that in no event the new salary be above the highest step of the promoted class.~~

Salary Upon Demotion

When an employee is demoted, the employee's compensation shall be adjusted to the salary which most closely reflects the employee's current salary step in the classification; provided in no event shall that new salary be above the employee's previous salary or the highest step of the lower classification.

Hours of Work

The work period for non-exempt employees shall be consistent with section 7(k) of the Fair Labor Standards Act - Overtime Compensation Rules.

The designated work period shall remain permanent and may be changed only as a result of major changes in operations, payroll procedures, or as otherwise necessary in order to deliver services as efficiently and economically as possible.

Unless otherwise designated by the Fire Chief, the workweek for all shift employees shall be from Sunday through the following Saturday and "work shift" shall mean "8:00 a.m. to 8:00 a.m.". Fire District shift employees will generally be held to a twenty-eight (28) day FLSA work period, forty-eight (48) hours on and ninety-six (96) hours-off schedule.

Scheduled and Emergency Work

Unless excused by the Fire Chief, an employee, upon request, shall not fail or refuse to perform emergency or scheduled work. Scheduled means at least twenty-four (24) hours prior notice. Failure or refusal of the employee to work in accordance with this provision shall be grounds for discipline.

All extra hours worked must have prior approval before being worked. The District will follow all State and Federal laws governing payment of FLSA overtime pay.



Cascade Fire Equipment
 PO Box 4248
 Medford OR 97501
 United States
<https://cascadefire.com/>
 (800) 654-7049

Quote
#QUO7094
 10/01/2025

Bill To

Redwood Valley Calpella Fire
 Po Box 385
 Redwood Valley CA 95470
 United States

Ship To

Redwood Valley Calpella Fire
 8481 East Rd
 Redwood Valley CA 95470
 United States

| Quote Expiration | Quote Name | Sales Rep | Shipping Method |
|------------------|--------------------------------|-------------|-----------------|
| 10/31/2025 | 125 Gallon End Mount Skid Unit | Dylan Clark | |

| Item | QTY | Rate | Amount |
|---|-----|-------------|-------------|
| Q200 125 Gallon End Mount Skid Unit | 1 | \$27,202.00 | \$27,202.00 |
| Subtotal | | | \$27,202.00 |
| Shipping Cost | | | |
| Tax Total (%) | | | \$2,142.16 |
| Total | | | \$29,344.16 |

Brush Truck Options:

125 GALLON END MOUNT SKID UNIT

- 125 gallon fully baffled poly tank / 10 gallon foam cell (CFE Foam Flo)
- 2" aluminum sub frame
- diamond plate tank top / diamond plate rear platform
- 18HP Briggs & Stratton motor / CF-120 pump
- Hannay steel electric hose reel
 - ¾"x100' 300psi booster hose, 1" Ranger nozzle
- stainless steel control panel
 - pressure gauge, on/off/start, throttle, choke, low pressure shut off
 - LED water / foam level gauges, foam controller
- stainless steel plumbing
 - 2" draft/suction, 2.5" hydrant fill, 1.5" discharge, 1" tank fill
- 5 gallon fuel cell, winterization system, electric primer



QUO7094

MTECH Inc.
 1072 MARAUDER STREET
 SUITE 210
 CHICO, CA 95973
 Phone: 530-894-5091
 Fax: 530-894-5092

Quotation

Quote WILL CALL
 To: REDWOOD VALLEY FIRE
 , CA

| | |
|-------------------------------|-----------------------------------|
| Quote Number: 18251 | Contact: KERRY ROBINSON |
| Quote Date: 10/03/2025 | Expires: 11/02/2025 |
| Customer: REDWOODVF | Inquiry: |
| Salesman: Steve Kleppe | Terms: Prepayment Required |
| Ship Via: WILL CALL | Phone: +1 (707) 489-2778 |
| FOB: CHICO, CA | FAX: |

1. This is an estimate only. Modification to line items may affect final pricing.
2. Price does not include sales tax (if applicable), crating or freight charges.
3. Commercial address with a forklift or loading dock is required to qualify for QTAC UTV skid flat rate shipping.

| <u>Item</u> | <u>Part Number</u> <u>Description</u> | <u>Revision</u> | <u>Quantity</u> | <u>Price</u> |
|-------------|--|-----------------|-----------------|-------------------|
| 1 | 2300.027-02 QTAC 150HP - Short bed - Versax-9 with Electric Reel Complete Package - (Red W/ White Graphics), Includes: - (1) 150-Gallon copolymer tank with pump platform - (1) Set, Forklift Pockets, Short bed - (1) Waterax Versax Two-Stage Pump (MAX 150 PSI, MAX 105 GPM) - (1) Honda GX270 9hp 4-cycle engine - (1) Hannay electric hose reel - (1) PolyTough battery box with onboard battery - (1) Black Commercial Grade Rubber Reel Hose, 3/4" X 100' - (1) Viper Nozzle with Pistol Grip, 10-23 GPM, 1" NST X 3/4" GHT Adapter - (1) 8" x 8" Water Fill Tower w/ hinged lid and trash screen - (1) Water Level Gauge - (1) 1-1/2" drain - (1) 2" Draft Suction - (1) 1" NPSH Auxiliary Discharge - (1) 1" Pump-to-tank Recirculation Valve - (1) 1" Pump to Hose Reel - All necessary hoses, clamps, and fittings for build - Approximate dimensions: 75" L x 47 5/8" W x 18 1/2" T | | 1 | \$14,065.0000 /EA |

Total: \$14,065.00

Steve Kleppe
 skleppe@qtacfire.com
 1-888-797-5100 EXT 166

By STEVEN KLEPPE
 MTECH Inc.

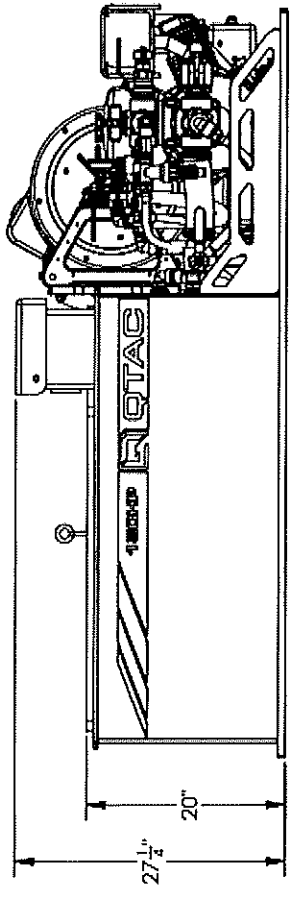
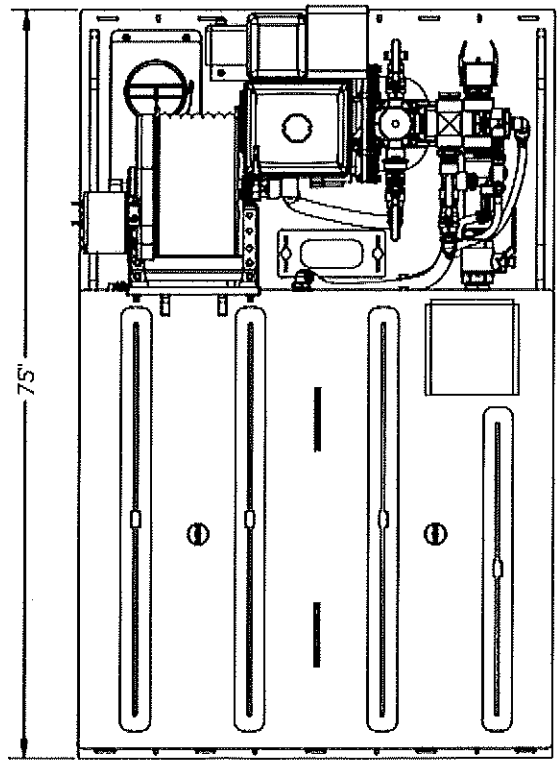
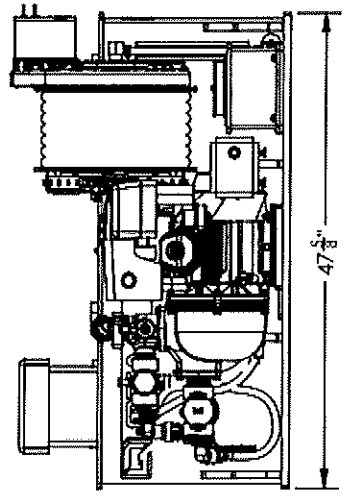
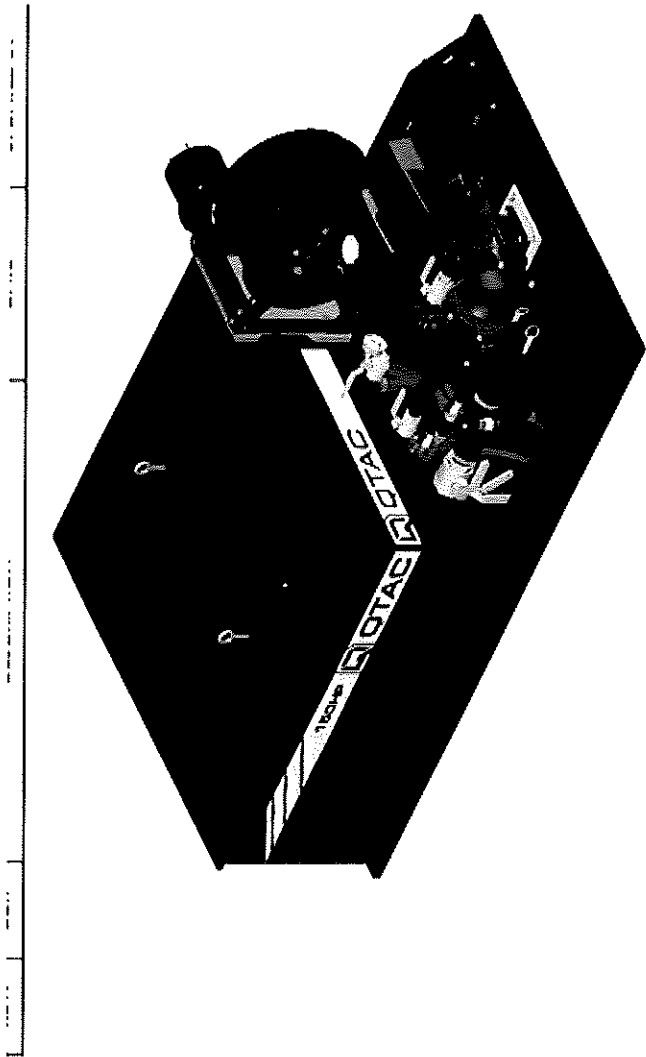

**REDWOOD VALLEY-CALPELLA
FIRE DISTRICT
Operating Procedures Manual**

OPM 3.24

Outdoor Warning Siren

Page 1 of 3

Section 3.24:1 Introduction

Outdoor warning sirens are a tool used by emergency officials to warn the public of an immediate threat to life safety from many types of hazards and threats.

Outdoor warning sirens are just one element in an integrated public warning system that uses many methods to provide immediate, life-saving warning to the public as quickly as possible. Other elements of the integrated public warning system include the National Oceanic and Atmospheric Administration's (NOAA) National Weather Radio (NWR); broadcast radio, television, and cable providers that use the Emergency Alert System (EAS); Wireless Emergency Alert (WEA) systems; telephonic notification services; and digital message boards along highways. No single piece of public warning technology is capable of alerting all people all the time. People engage in various activities throughout the day and these warning tools may, or may not, be effective for reaching an individual at any particular moment. Having a variety of warning tools provides redundancy and resilience against failure of key systems such as cell phone towers, the internet, or electrical service; which happens often when disaster strikes.

Section 3.24:2 Organization and Capabilities

RVCFD's newer outdoor warning siren is not part of a centralized county-wide system. The outdoor siren is located at the District's station at 8481 East Road, Redwood Valley. The only way to activate the outdoor warning siren is from inside the station or remotely via telephone. The original outdoor warning siren was installed as a way to call volunteer firefighters to the main station for emergency response. That purpose was long ago replaced by pagers, radios and cell phones. Prior to going out of service and being decommissioned, the original outdoor warning siren was sounded once a day at noon simply to mark the lunch hour.

The deadly fires of October, 2017, revealed a need for a better emergency alarm system in Redwood Valley. Outdoor sirens have been identified as an important component of an integrated warning system. Following the installation of the newer outdoor warning siren, the County of Mendocino commissioned a feasibility study to expand outdoor warning sirens throughout Redwood Valley. The study concluded that it was not feasible due to the number of sirens needed for the area.

The RVCFD has two forms of outdoor warning sirens available to it for emergency warnings: the newer stationary outdoor warning siren and the vehicle sirens (Hi/Low) that are incorporated into every RVCFD emergency vehicle.

**REDWOOD VALLEY-CALPELLA
FIRE DISTRICT
Operating Procedures Manual**

OPM 3.24

Outdoor Warning Siren

Page 2 of 3

Outdoor warning sirens are a tool to warn people who are outdoors to take immediate, potentially life-saving action by finding shelter from an imminent deadly threat. The public should know that hearing an outdoor warning siren is a call to take immediate life-saving action. The desired individual action is to take shelter, get inside and get information. For the most part, sirens warn those outside. Television screen crawlers warn those watching TV. Digital message boards and radios warn those driving. Weather alert radio and wireless emergency alerts warn those who are inside the home or business, or who are mobile and outside the area.

Two Siren Tones: There are two basic sounds or tones used by the newer outdoor warning siren; 1) Situational Awareness and, 2) Evacuation.

1. Situational Awareness is a steady “wail” tone for 60 seconds followed by 60 seconds of silence. Repeats cycle five times.
2. Evacuation is a Hi/Low tone for 30 seconds followed by 30 seconds of silence. Repeats cycle continuously until reset.

RVCFD should consider upgrading the Command and Control system to a CPU/GUI Software application that gives more features for operational control such as integration to the National Weather Services (NWS) for auto activations of emergencies and/or email of emergency groups on activation, tests and alerts.

Section 3.24:3 Operational Standards

Local emergencies that may require siren activation include, but are not limited to, dangerous weather events such as extreme winds; fire that is completely out of control and threatens entire neighborhoods; deadly chemical or hazardous material releases; or certain active security situations. The message that emergency officials want to communicate to the public by using outdoor warning sirens for Situational Awareness is to find protective shelter to “get inside and then get information”.

When used for public warning of a local emergency for Evacuation, the RVCFD outdoor warning siren will sound the Hi/Low alert sound.

No “All Clear” tone will ever be sounded. For weather events and hazardous emergencies, the idea that there is an “all-clear” tone is dangerous. The “get inside and get information” concept is supposed to have people move inside to sturdy shelter and then connect with an information source, such as radio. The all-clear will come from broadcasts and other sources while people remain in the sheltered or evacuated location.

**REDWOOD VALLEY-CALPELLA
FIRE DISTRICT
Operating Procedures Manual**

OPM 3.24

Outdoor Warning Siren

Page 3 of 3

Section 3.24:4 Periodic Tests

To verify that the siren is working, the RVCFD stationary outdoor warning siren shall be tested on a biannual basis. It is important that people in listening range of outdoor warning siren fully understand the intent behind biannual siren tests. Public education efforts should make it clear that siren tests are provided as a way for people to become familiar with the siren tones that they will hear for a warning. They should learn how siren sounds carry in various weather conditions. During these tests people can actually move to a place of shelter, or they can do a quick mental assessment of what they would do in an actual emergency.

Too many tests however cause a condition called “siren fatigue” in which people have become numb to siren sounds and their attention is no longer secured when a siren goes off. For that reason, the siren shall be sounded only biannually, at 12 noon on the first Tuesday in May and November. At that time the Situational Awareness tone shall be sounded.

Section 3.24:5 Activation

The outdoor siren emergency alert system will be activated by qualified personnel or automated programming when the following conditions are present:

- a. When it has been visually confirmed that severe/damaging winds will be impacting the community of Redwood Valley and/or the National Weather Service has issued a severe storm/high wind warning indicating those winds monitored with gusts in excess of 58 mph.
- b. When a fire has been determined to be out of control and RVCFD efforts are reduced to saving lives, not fighting or containing the fire. This is most likely to occur at times of high winds, when several structures or large expanses of woodland are on fire at the same time. During this type of emergency event, the sounding of the station siren shall be augmented with sirens by all responding emergency vehicles.
- c. Any situation defined by the County of Mendocino, the State of California or the Federal Government as a threat to national security, a major hazardous materials spill or other major threat to the safety of the American public.



REDWOOD VALLEY-CALPELLA FIRE DISTRICT

Delbert Phelps Fire House
8481 East Road
Redwood Valley CA 95470
707-485-8121

Dan Grebil
Interim Fire Chief

MEMORANDUM

Date: October 6, 2025
To: Board of Directors
From: Dan Grebil, Interim Fire Chief
Subject: October 9, 2025 – Agenda Item 6.2 - Fire Chief Report

Information/Discussion

61 Incidents including 1 fire for September 2025

September training topics included:

Association Business Meeting, Rescue Ropes (two sessions including 3 to 1 hauling operations) and EMS Backboarding/Rescue Stokes Basket.

Personnel:

Career – New Permanent Fire Chief selected...

Acting Fire Apparatus Engineer/Duty Officer begins permanent appointment on October 19th.

Volunteer – Roster = 22 (one resignation and two pending applications)

Explorer – Roster = 4 (one pending application)

Equipment: Surplus Sold – Portable Radios and Accessories totaling \$1,000

Water Tender 6290 at City Yard – upsizing hydraulic pump hoses/lines.

E6280 got wrapped, new wheels/rims and drive tires. Work party planned to take E6283 out of service and place E6280 into service.

The County Board of Supervisors approved our request to utilize PG&E Disaster Settlement Funds for the purchase and equipping the replacement for Rescue 6230.

BOARD OF DIRECTORS

Joe Cooper

Stephanie Dunken

Ryan Mayfield

Russel Odell

James Tusso



Redwood Valley Calpella Fire Department



Fire Programs Report

SEPTEMBER 2025 Incidents By Type, Summary

| | | |
|--|----|------------------|
| 1 - Fire | | Count: 1 |
| 112 - Fires in structure other than in a building | 1 | |
| 3 - Rescue & Emergency Medical Service Incident | | Count: 28 |
| 311 - Medical assist, assist EMS crew | 20 | |
| 320 - Emergency medical service incident, other | 1 | |
| 321 - EMS call, excluding vehicle accident with injury | 5 | |
| 324 - Motor vehicle accident with no injuries. | 2 | |
| 4 - Hazardous Condition (No Fire) | | Count: 1 |
| 400 - Hazardous condition, other | 1 | |
| 5 - Service Call | | Count: 13 |
| 551 - Assist police or other governmental agency | 4 | |
| 552 - Police matter | 1 | |
| 553 - Public service | 1 | |
| 5531 - Lift Assist | 7 | |
| 6 - Good Intent Call | | Count: 13 |
| 611 - Dispatched & canceled en route | 11 | |
| 622 - No incident found on arrival at dispatch address | 1 | |
| 652 - Steam, vapor, fog or dust thought to be smoke | 1 | |
| 7 - False Alarm & False Call | | Count: 5 |
| 733 - Smoke detector activation due to malfunction | 2 | |
| 735 - Alarm system sounded due to malfunction | 3 | |

Report Total: 61



Redwood Valley Calpella Fire Department



Fire Programs Report

September 2025

Incident Details

Grouped by: Incident Date

| | |
|-------------------|-----------------|
| 09/29/2025 | Count: 1 |
|-------------------|-----------------|

Incident Number: 2025519

Dispatch: 09/29/25 18:52

Incident Type: 112 - Fires in structure other than in a building

Apparatus: 5

Location: 17001 Tomki RD, Redwood Valley, CA 95470

Personnel: 10

Total Incidents: 1



REDWOOD VALLEY-CALPELLA FIRE DISTRICT

Delbert Phelps Fire House
8481 East Road
Redwood Valley CA 95470
707-485-8121

Dan Grebil
Interim Fire Chief

September 15, 2025

Board of Supervisors
County of Mendocino
501 Low Gap Rd., Room 1010
Ukiah, CA 95482

Dear Board of Supervisors,

This letter serves to request your consideration in the re-programming of 2017 Wildfire PG&E Settlement Funds that were allocated to the Redwood Valley-Calpella Fire District for projects, that grant agreements were never drafted, to a new project for the purchase of a replacement Light Rescue Unit and Rescue Equipment.

Delete these three projects totaling \$360,000:

Locks for Fire Hydrants - \$150,000
Four warning sirens and poles - \$135,000
Clean-up from the 2017 Fire - \$75,000

Add a new project and initiate a grant agreement between the County of Mendocino and the Redwood Valley-Calpella Fire District totaling \$360,000:

New Light Rescue Unit with Rescue Equipment - \$360,000

Thank you for your consideration in this matter.

Please contact me directly with any questions or concerns regarding this request.

Respectfully,

Dan Grebil
Interim Fire Chief

BOARD OF DIRECTORS

Joe Cooper

Stephanie Dunken

Ryan Mayfield

Russel Odell

James Tuso

- 3i) **Approval of Agreement (First Amendment to Agreement No. EO-23-29) with CivicPlus, LLC., in the Amount of \$2,173.01, for a New Total of \$26,173.01, to Provide Municode Codification Services, Effective January 20, 2023, through a New End Date of January 30, 2026 (Original End Date: January 19, 2026), with Annual Automatic Renewals**

Recommended Action:

Approve Agreement (first Amendment to Agreement No. EO-23-29) with CivicPlus, LLC., in the amount of \$2,173.01, for a new total of \$26,173.01, to provide Municode Codification Services, effective January 20, 2023 through a new end date of January 30, 2026 (original end date: January 19, 2026), with annual automatic renewals; authorize the Chief Executive Officer or designee to sign any future amendments that do not increase the maximum amount; and authorize Chair to sign same.

Attachments: Agreement

Original Agreement - CivicPlus, LLC., 22-26, COB, EO-23-29

- 3j) **Approval of One-Time Funding Agreement with Covelo Fire Protection District in the Amount of \$66,000, to Support Basic Life Support Services in the More Rural Areas of Mendocino County, Effective Upon Full Execution through June 30, 2026**

Recommended Action:

Approve one-time funding Agreement with Covelo Fire Protection District in the amount of \$66,000, to support Basic Life Support services in the more rural areas of Mendocino County, effective upon full execution through June 30, 2026; authorize the Chief Executive Officer or designee to sign any future amendments to the Agreement that do not increase the maximum amount; and authorize Chair to sign same.

Attachments: Agreement

- 3k) **Approval of Request by Redwood Valley-Calpella Fire District (RVCFD) to Reallocate One-Time Pacific Gas and Electric Disaster Settlement Funds, in the Amount of \$360,000, for the Purchase of a New Light Rescue Unit and Rescue Equipment**

Recommended Action:

Approve request by Redwood Valley-Calpella Fire District (RVCFD) to reallocate one-time Pacific Gas and Electric Disaster Settlement Funds, in the amount of \$360,000, for the purchase of a new light rescue unit and rescue equipment; and authorize the Chief Executive Officer or designee to sign the Agreement and any amendments that do not increase the maximum contracted amount.

Attachments: Reallocation Request

Approved by
County BOS